

SFGB

GRAVIMETRIC BLENDERS

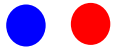

SCOPE:

Dosing plastic materials for beside machine installations.

TECHNOLOGY:

weight control.

APPLICATIONS:

injection mouldings, extruders and blowers up to 2.750 Kg/h capacity.*

TYPE OF MATERIALS MANAGED:

plastic granules (virgin and regrind) and additives.

* The throughput depends on the number of components, material characteristics, bulk density and percentages.





If money in the market is so scarce, and rare, to spend it you need really good reasons.





KEY-POINTS

SFGB	MINI	1.5	2	5	10	25
<i>Accuracy:</i> the system will weigh to an accuracy of 1/100 of a gram. Dependent on the interface, the display will show the weight of each component in 1 gram or 1/10 of a gram.	S	S	S	S	S	S
<i>Auto-adapting and constant dosing:</i> the right receipt is calculate with the first sample and then is manteind by a precise opening/closing time of the valves. It means that it's not necessary to set the weight of the "in-flight" material.	S	S	S	S	S	S
<i>Receipt composition:</i> the receipt can be composed in weight (grams) or in percentaige on the total weight and it's also possible to control the order of the components in dosing.	S	S	S	S	S	S
<i>Touch screen</i> plug-in interface (microprocessor controlled)	S	S	S	S	S	S
<i>Sophisticated industrial PC with touch screen</i> for the total control and supervision of centralized application.	O	O	O	O	O	O
<i>Regrind management:</i> the design of the valves in the bottom of the hoppers is different for virgin (plastic and additives) and regrind materials, in order to guarantee the best performance in recycling.	S	S	S	S	S	S
<i>Special materials:</i> all construction and material contact parts are in stainless steel.	S	S	S	S	S	S
<i>Flexible throughput:</i> the mixing chamber of the dosing units is provided with a level sensor which controls the quantity of material in order to follow the "up and down" production of the transforming machine.	S	S	S	S	S	S
<i>Low-level control:</i> all material hoppers can be equipped with low level sensors for an additional warning.	O	O	O	O	O	O
<i>Real time control</i> of the machine working conditions and eventual alarms.	S	S	S	S	S	S
 <i>Swan technology</i> allows the possibility of customizing the software for special needs.	O	O	O	O	O	O
 "Recycling is <i>more</i> than a business": recycling etchical approach is orientid to save costs and respect ambient.	S	S	S	S	S	S

S = Standard O = Optional



APPLICATIONS (EXAMPLES)

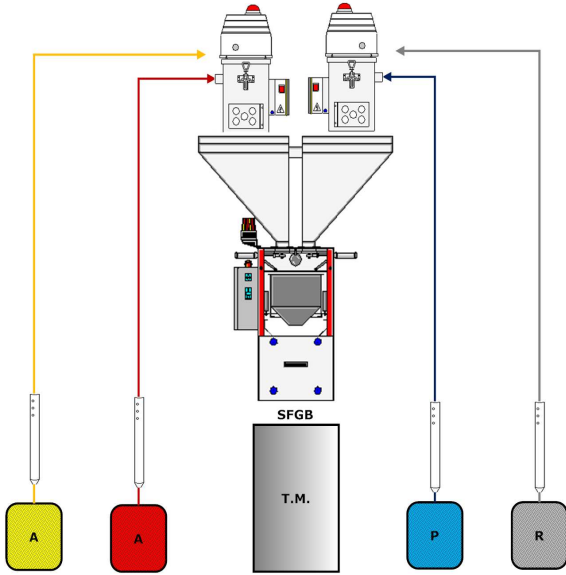

SFGB – Installation directly on transforming machine (4 components dosing)

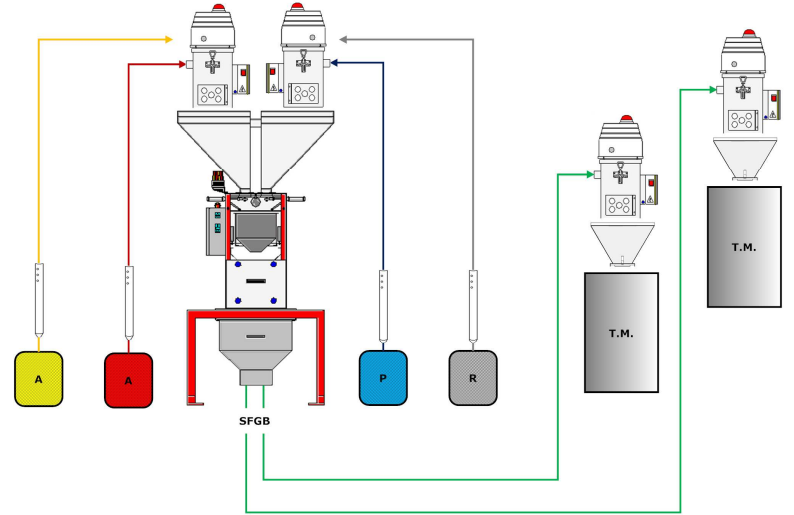

SFGB – Installation beside transforming machines with 2 ways conveying (4 components dosing)

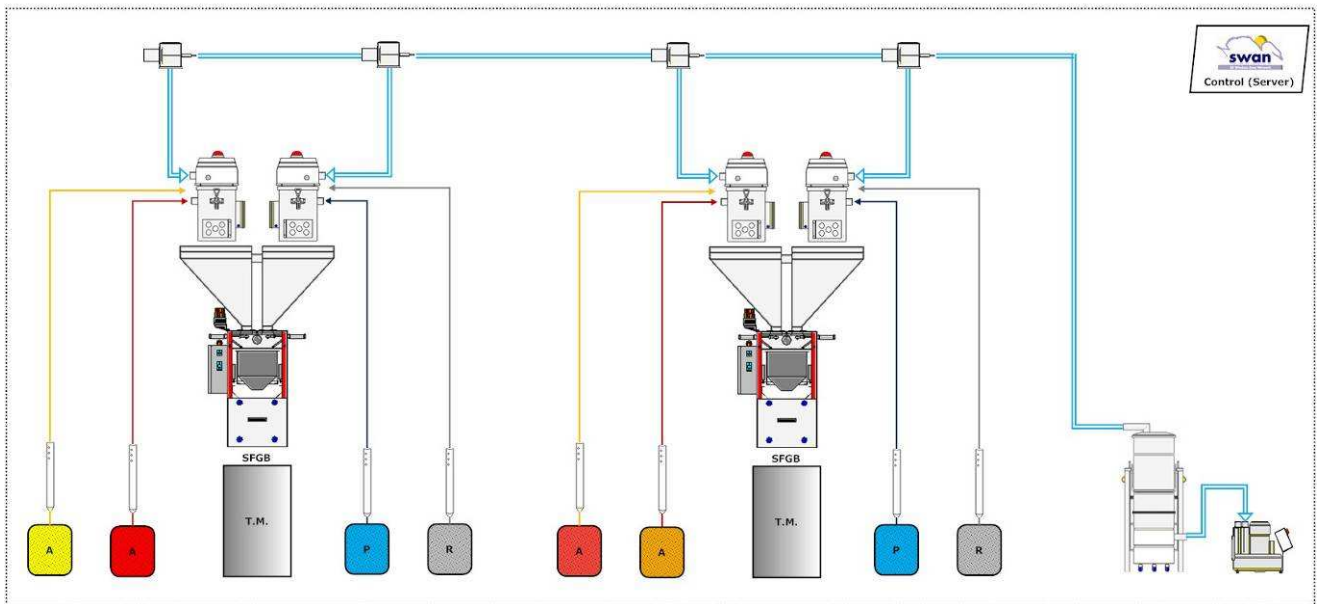

SFGB – Installation directly on transforming machines with centralized feeding system (4 components dosing)





TECHNICAL DATA

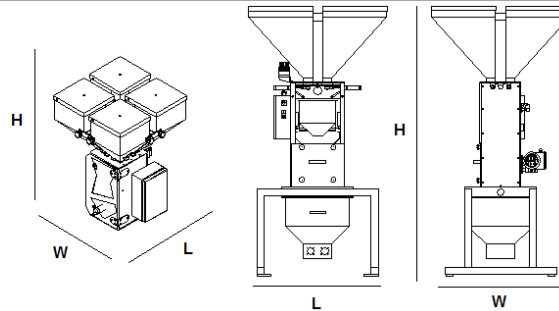

	Mod.	SFGB MINI	SFGB 1.5	SFGB 2	SFGB 5	SFGB 10	SFGB 25
Batchweight	Kg	0,5	1,5	2	5	10	25
Number of components (max)	Nr	4	4	2 up to 6	2 up to 6	2 up to 7	2 up to 10
Throughput *	Kg/h	50 (with 4 components)	300 (with 4 components)	420-195	945-355	1800-750	2750-1000
Capacity of material hoppers	Lt	6	7,5 - 11	35 - 85	35 - 85	80 (central hopper)	160 or 2x80 (central hopper)
	Lt	/	/	/	/	50 (side hoppers)	70 (max 6 hoppers)
	Lt	/	/	11 (tube feeder)	11 (tube feeder)	/	25 (tube feeder)
Valves	Nr	Up to 4 dosing valves	Up to 4 slide valves	Up to 4 slide valves / 2 auger feeders	Up to 4 slide valves / 2 auger feeders	Up to 7 slide valves	Up to 8 slide valves / 2 auger feeders
Power supply	V / Hz	240V / 50-60Hz			400V / 50-60Hz (3P+N+PE)		
Max power consumption	kW	0,05	0,15	0,45	0,45	0,55	1,1
Compressed air supply	Bar	6	6	6	6	6	6
Compressed air consumption	Nl/h	60	60	250	250	± 250	± 250
Dimensions **	W mm	450	600	950	950	950	1750
	L mm	450	700	950	950	950	1750
	H mm	685	805	1115	1265	1115	2150
Weight **	Kg	35	60	75	80	300	400
Dimensions (stand/box)	mm	/	/	780 x 650 x 810	780 x 850 x 610	1000 x 1000 x 630	1500 x 1500 x 730
Capacity of take-off box	Lt	/	/	± 55	± 55	± 110	± 220

* The throughput depends on the number of components, material characteristics, bulk density and percentages.

** The dimension and weight depends on the configuration of the blender.

SB Plastics Machinery Srl

Via Del Lavoro, 11 – 35010 Vigodarzere (PD) – ITALY

Tel.: 049/8843047 - Fax: 049/8843604 - Web: www.sbplastics.it - www.sb-ird.com

ISO 9001-2000

A290

